

PRODUCT DATA SHEET

Ramén Ball Sector Valve type KS-1C



Ramén Valves

We know the flow

DN 40-300 | Wafer | PN 40 | Stainless steel | Metal Seat | Viton®



The Ramén Ball Sector Control Valve in material configuration 1C is a stainless steel control valve with a Stellite metal seat and hard chrome coated ball sector and seat holding ring.

KS-1C is used for abrasive media at moderate pressure or pressure drop. KS-1C is also well suited for applications with elevated velocity or pressure drop and with incipient cavitation.

Typical applications

- Slurries
- Liquor (Green, white & black)
- Low pressure steam
- Chemicals
- Water & waste water
- Process water

Technical information		
Design		Flangeless, wafer type (size DN 300 flanged)
Nominal sizes		DN 40 - DN 300, 1"-12"
Material	Body Shafts Ball Sector Seat Seat holding ring O-rings Bearing	EN 1.4409, AISI 316L EN 1.4460, AISI 329 EN 1.4409 +Cr, AISI 316L+Cr Stellite EN 1.4409+Cr, AISI 316L+Cr Viton® Rulon®
Nominal pressure	DN 40- DN 50 DN 80 - DN 100 DN 150 - DN 250 DN 300	PN 40 (for flange PN 10/40 and ANSI 150/300/600) PN 25 (for flange PN 10/25 and ANSI 150/300) PN 16 (for flange PN 10/16 and ANSI 150) PN 16 (Flanged PN 16 or ANSI 150)
Operating temperature*		-40° C - 250° C, -40° F - 482° F
Seat leakage class according to EN60534-4		IV
Shell test according to EN12266-1		No leakage detectable
Characteristic		Equal percentage
Rangeability		Up to 300:1
Options	O-rings Alloy steels Seat	EPDM, Nitril, Kalrez®, Viton GLT, EPDM 90 904L, 304, 316L, 254 SMO, Hastelloy, Duplex, Super Duplex, Titanium White PTFE, PEEK
Certificates and approvals		CE marked acc. to PED 2014/68/EU, Category II, Module D1 ATEX according to directive 2014/34/EU FDA approved elastomer (O-ring) as an option

*Depending on sealing material

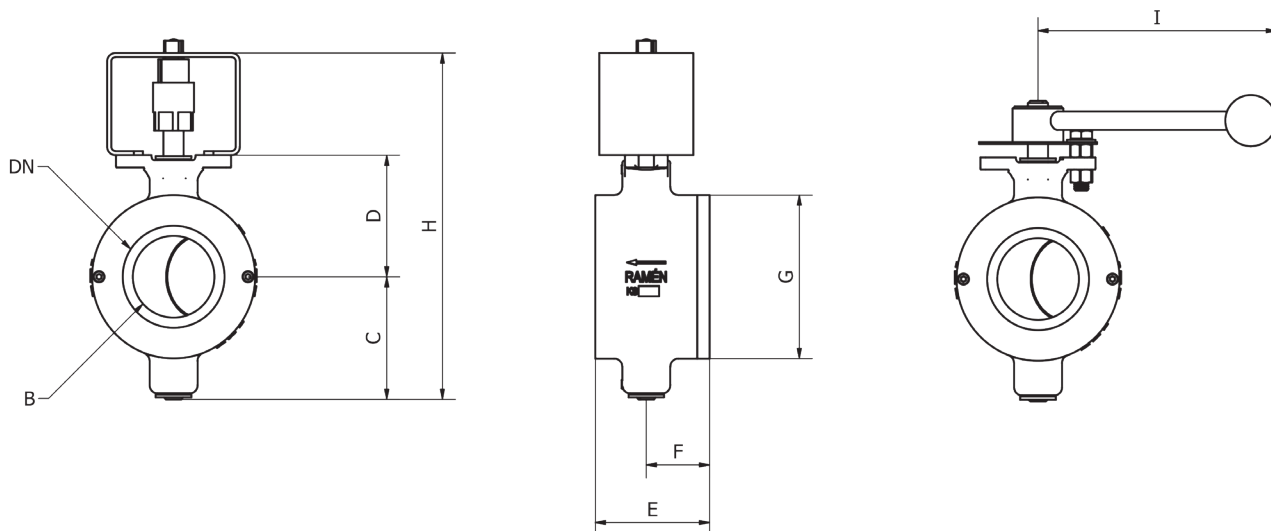

Dimensions								
DN	40	50	80	100	150	200	250	300
B Bore [mm]	25 32	40	64	80	120	150	195	250
C [mm]	95	95	107	118	167	188	233	310
D [mm]	95	95	107	118	167	188	233	310
E [mm]	71	71	95	112	170	210	270	368
F [mm]	38	38	55	62	95	120	150	198
G [mm]	94	94	140	160	220	274	330	460
H [mm]	250	250	315	337	454	503	561	710
I [mm]	160	160	290	290	370	370	N.A.*	N.A.*
Weight [kg]	4	4	8	12	25	38	67	170
Top mounting flange* EN-ISO 5211	D14/D17 F05/07	D14/D17 F05/F07	D17/D22 F05/F07	D17/D22 F10/F12	D22/D27 F10/F12	D22/D27 F10/F12	D27 F10/F12	D36 F14

* Gear boxes available on request

** D refers to diagonal square size & F refers to hole pattern.

Technical specifications									
DN	40	50	80	100	150	200	250	300	
Kvs [m ³ /h]	34 64	94	255	390	810	1365	2220	3840	
Cv [gpm]	40 75	110	300	460	950	1600	2600	4500	
Actuator torque [Nm]	Recommended*	30-90	30-90	80-200	160-400	160-400	160-400	250-600	700-1200
	Max.	100	100	200	400	400	400	700	2000
Rotation angle	30°-90° 20°-90°	0°-90°	0°-90°	0°-90°	0°-90°	0°-90°	0°-90°	0°-90°	

* The lower value of the torque range can be used for on-off applications for clean media at normal temperatures. The higher value of the torque range shall be used for pneumatic actuators with positioner when high control accuracy is needed or for dirty/sticky media.

Exploded view DN 40-250

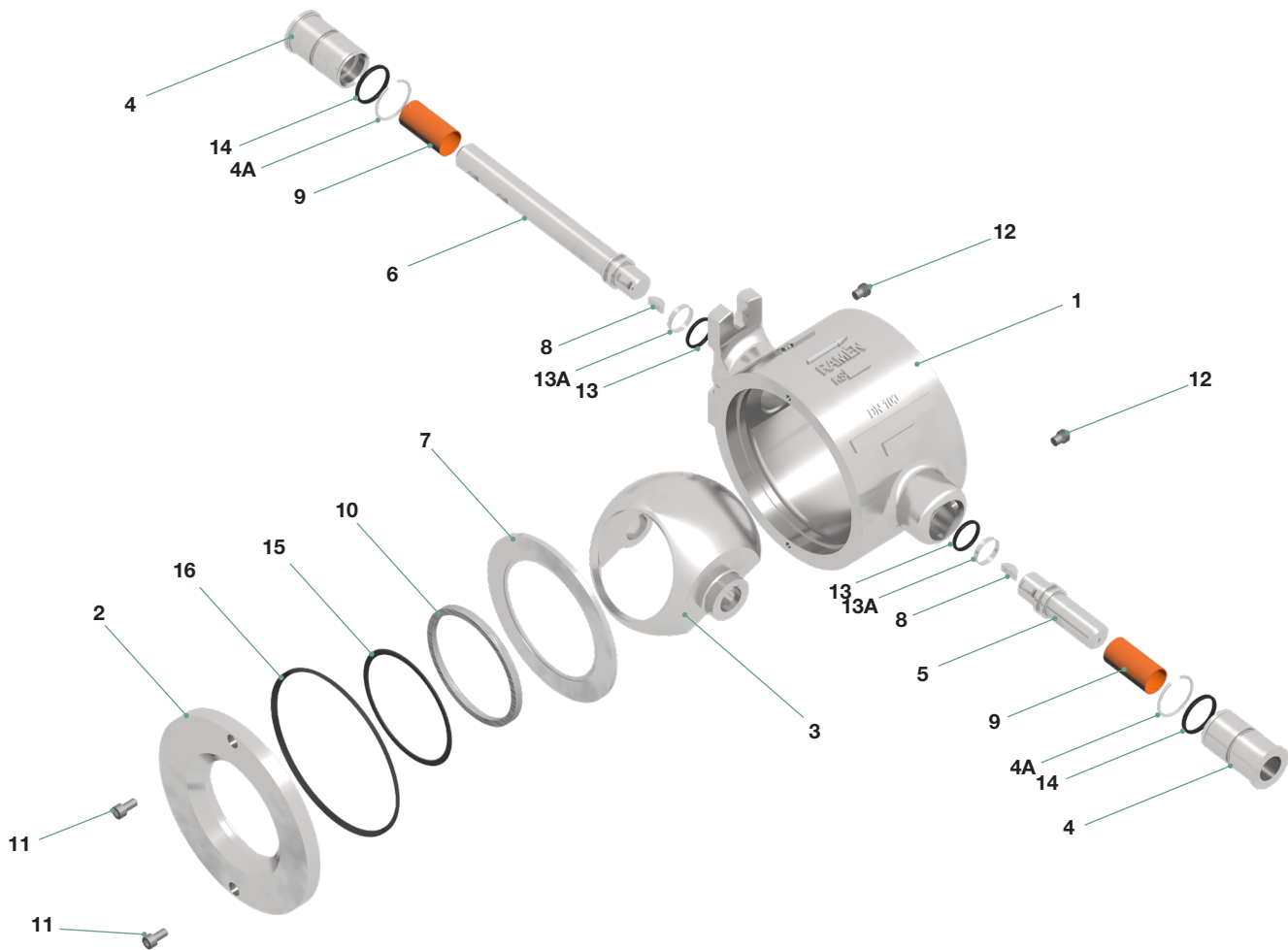

Parts list DN 40-250

Part	QTY	Name	Material
1	1	Body	EN 1.4409 (AISI 316L)
2	1	Seat holding ring	EN 1.4409 (AISI 316L) +Cr*
3	1	Ball sector	EN 1.4409 (AISI 316L) +Cr*
4	2	Bearing sleeve	EN 1.4460 (AISI 329)
4A	2	Safety ring	EN 1.4409 (AISI 316L)
5	1	Shaft (trunnion)	EN 1.4460 (AISI 329)
6	1	Shaft	EN 1.4460 (AISI 329)
7	1	Seat support ring	EN 1.4409 (AISI 316L)
8	2	Woodruff key	EN 1.4460 (AISI 329)
9	2	Bearing	Rulon®
10	1	Seat ring	Stellite
11	2	Screw	EN 1.4409 (AISI 316L)
12	2	Grub screw	EN 1.4409 (AISI 316L)
13	2	O-ring	Viton® (FKM)
13A	2	Sliding ring	PTFE
14	2	O-ring	Viton® (FKM)
15	1	O-ring	Viton® (FKM)
16	1	O-ring	Viton® (FKM)

Standard spare part kit

Part	Name
9	Shaft bearing
10	Seat ring
13A	Sliding ring
13, 14, 15, 16	O-rings

*Hard-chromed

All materials acc. to standard configuration. Please contact your contact for order specific materials.

Exploded view DN 300

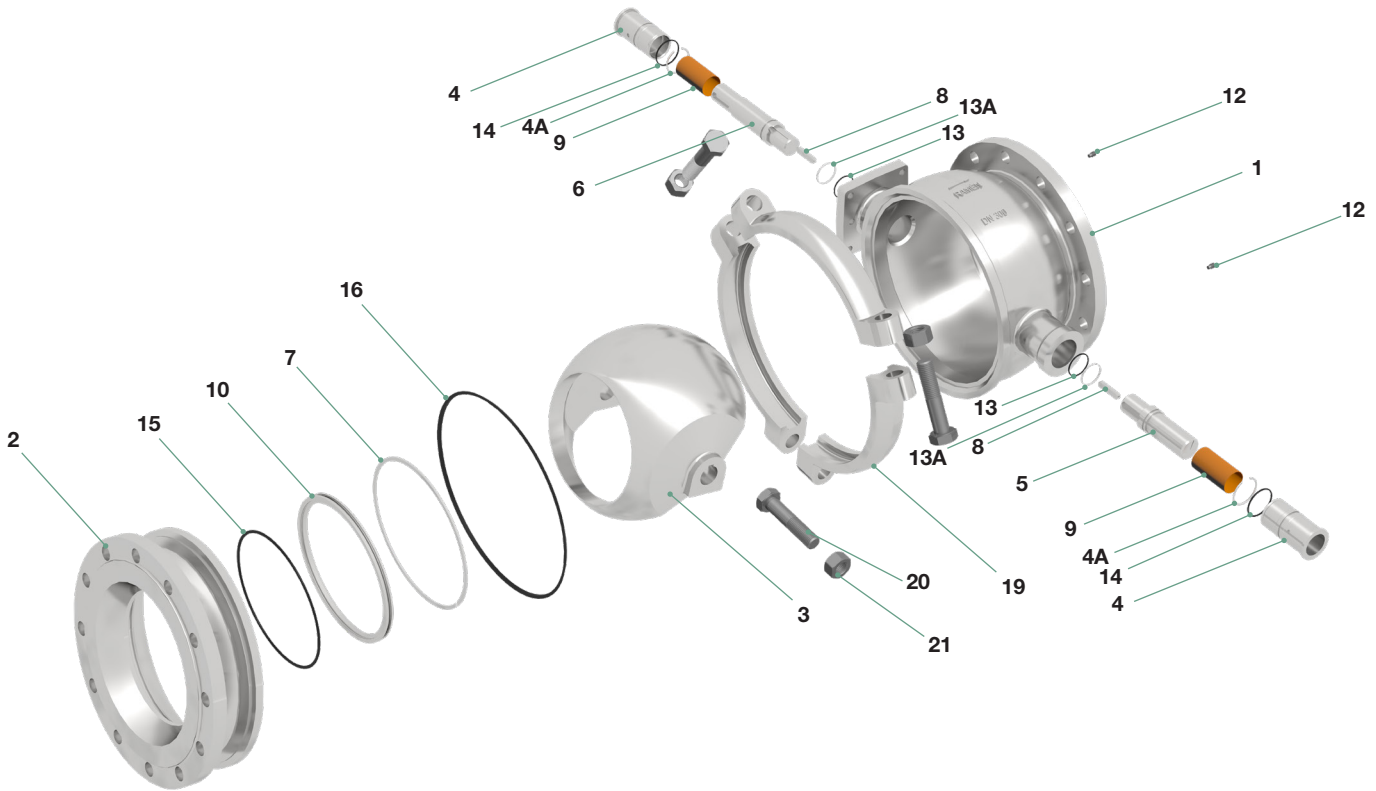

Parts list DN 300

Part	QTY	Name	Material
1	1	Body	EN 1.4409 (AISI 316L)
2	1	Seat holding ring	EN 1.4409 (AISI 316L) +Cr*
3	1	Ball sector	EN 1.4409 (AISI 316L) +Cr*
4	2	Bearing sleeve	EN 1.4460 (AISI 329)
4A	2	Safety ring	EN 1.4409 (AISI 316L)
5	1	Shaft	EN 1.4460 (AISI 329)
6	1	Shaft	EN 1.4460 (AISI 329)
7	1	Seat support ring	EN 1.4409 (AISI 316L)
8	2	Key	EN 1.4460 (AISI 329)
9	2	Bearing	Rulon®
10	1	Seat ring	Stellite
12	2	Grub screw	EN 1.4409 (AISI 316L)
13	2	O-ring	Viton® (FKM)
13A	2	Sliding ring	PTFE
14	2	O-ring	Viton® (FKM)
15	1	O-ring	Viton® (FKM)
16	1	O-ring	Viton® (FKM)
19	1	Clamp ring	EN-GJS-400
20	3	Screw	C.St. Zn.Pl.
21	3	Nut	

Standard spare part kit

Part	Name
9	Shaft bearing
10	Seat ring
13A	Sliding ring
13, 14, 15, 16	O-rings

*Hard-chromed

All materials acc. to standard configuration. Please contact your contact for order specific materials.

YOUR CONTACT FOR THE NETHERLANDS:

Binder Engineering B.V

Cort van der Lindenstraat 25
2288 EV Rijswijk
Tel. 070-307.4300
sales@binder-engineering.nl
www.binder-engineering.nl